

Caston III

Crane Scale

- Available in 10000 lb × 5, 20000 lb × 10, 30000 lb × 20, 40000 lb × 20, 60000 lb × 20 100000 lb × 50 Capacities
- Easy to Read 1.5" LED Display
- Wireless Remote Control Standard
- Environmentally Sealed to IP 67 Standards.
- Battery Operated



ISO 9001 certified

CAS
S · C · A · L · E

CASTON III Crane Scale

FEATURES

- Battery Operated w/Low Battery Indication
- Rechargeable Battery Pack
- Spare Battery Pack and Charger Included as Standard
- Easy to Read 1.5" LED Display
- Remote Control Included as Standard
- On,Off, Zero, Tare and Hold(Manual or Automatic) Functions
- Auto Span Adjustment
- Auto Zero Tracking

SPECIFICATIONS

Model	5THD	10THD	15THD	20THD	30THD	50THD
Weighing Capacity	10000×5lb 5000×2kg	20000×10lb 10000×5kg	30000×20lb 15000×10kg	40000×20lb 20000×10kg	50000×20lb 30000×10kg	100000×50lb 50000×20kg
Maximum Tare	Full Tare					
Display Type	LED(1.5 inch)					
Operating Power	DC 6V					
Power Source	AC 120V, 50/60Hz					
Display Designators	Zero, Tare, Hold, Batt.					
Power Consumption	1.2W					
Operating Temperature	- 10°C - +40°C (14°F - 104°F)					



▲ Display & Keyboard

◀ Battery pack Installation

DIMENSIONS

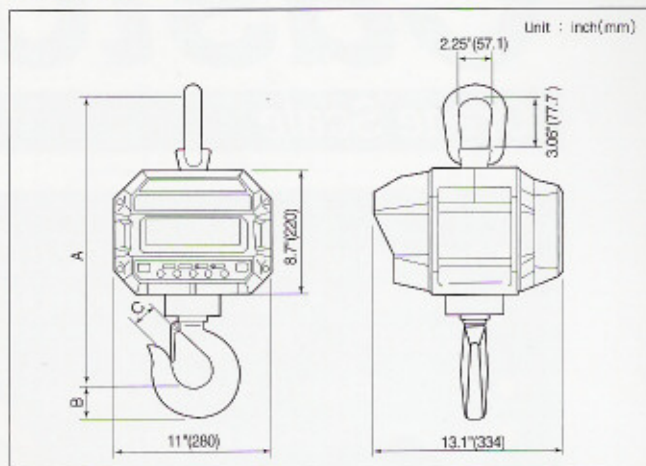

Model	A	B	C	Product Weight
5THD	20.1"(512)	1.75"(44.5)	1.69"(42.9)	68.3 lb / 31 kg

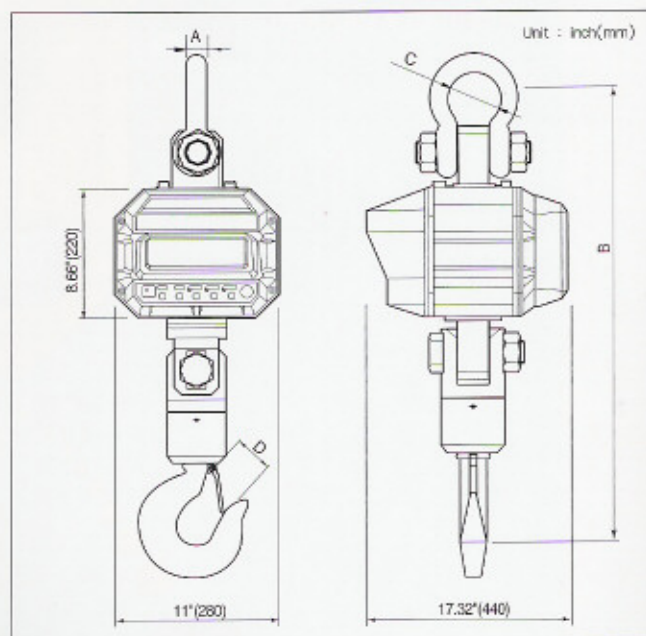

Model	A	B	C	D	Product Weight
10 THD	1.26"(32)	33.27"(845)	3.27"(83)	2.25"(57.2)	97 lb / 44 kg
15 THD	1.50"(38)	34.88"(886)	3.90"(99)	2.50"(63.5)	116.7 lb / 53 kg
20 THD	1.77"(45)	38.98"(990)	4.96"(126)	3.39"(86)	167.5 lb / 76 kg
30 THD	1.97"(50)	47.24"(1,200)	5.43"(138)	4.25"(108)	484.6 lb / 220 kg
50 THD	2.56"(65)	59.84"(1,520)	7.08"(180)	5.75"(146)	859.8 lb / 390 kg

ONE DIGITAL SCALES.com

Call Us Toll-Free

800-620-7811

www.onedigitalscales.com